

MMg

MMg scrubbing machines.

'not just a scrubbing machine, but a new approach to cleaning!'



**AFFORDABLE
cleaning**

MMg 65/75/85 B (2 disc brushes)

MMg 70 S (1 cylindrical brush)

MMg

Innovations



Fully optimized energy management

Same performances with lower consumption – clean more with less
Up to 4 hours working time with 210 Ah C5 batteries



- Brush deck really easy and compact, ideal for maintenance/cleaning
- Brush deck pressure adjustable from 30 Kg up to 60 Kg to suit the level of cleaning
- Low consumption traction motor with extra power ramps device

FSS; FimapSolutionSaver

FSS dosing system reduces water and detergent consumption by up to 50%, offering longer cleaning time and more productivity



One chemical refill delivers up to 10 full solution tanks



No bespoke chemical required, **all** suitable floor care detergents are compatible



FWF, FimapWaterFlow:
Even water flow to both brushes.
Reduced water consumption.

Eco ON/OFF System:
Water flow and brush rotation stops when machine stops



Fimap Noise Canceling

Noise insulated to 58dB without comprising suction performance or motor cooling.

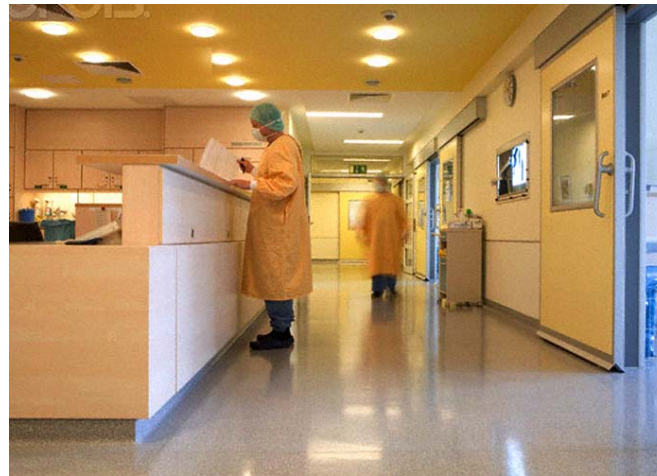

Only 58 dB (A)

It is possible to use this machine even in places where low noise is extremely important

Optional 3-stages suction motor for uneven floors

MMg

Innovations

Variable Deck

Easily adjustable working
width from 65 to 85 cm



Variable working width.

MMg

Innovations

Scrubbing & Sweeping

One single brush

Vacuumated hopper

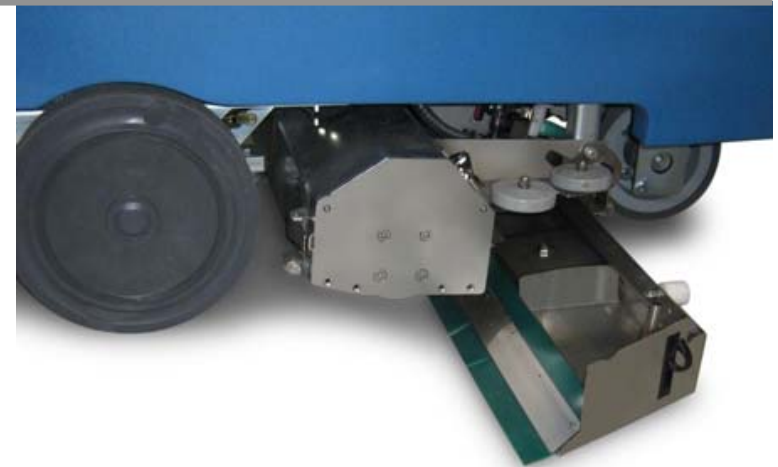
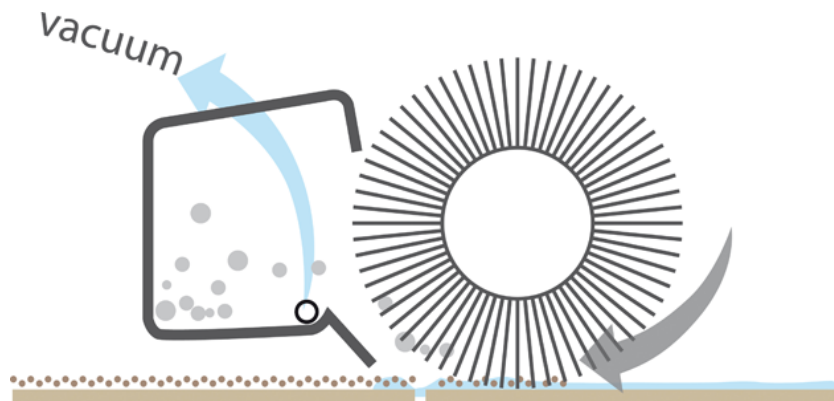

Cylindrical brush with suction in the debris hopper to collect solid waste.

Made in stainless steel

MMg

'Down time' reduced

Machine operation

Easy water refill



Hose fill option offers spill free control

Optional Fimap Fast Fill



FFF free's up operator time

Solution control



Up to 10 full tanks per 5L.
Detergent quick to refill

Comfortable



Standard, large, ergonomic and comfortable seat.
More comfort for longer cleaning

MMg

User-friendly

... during the cleaning operation

Intelligent Drive
Program
selector

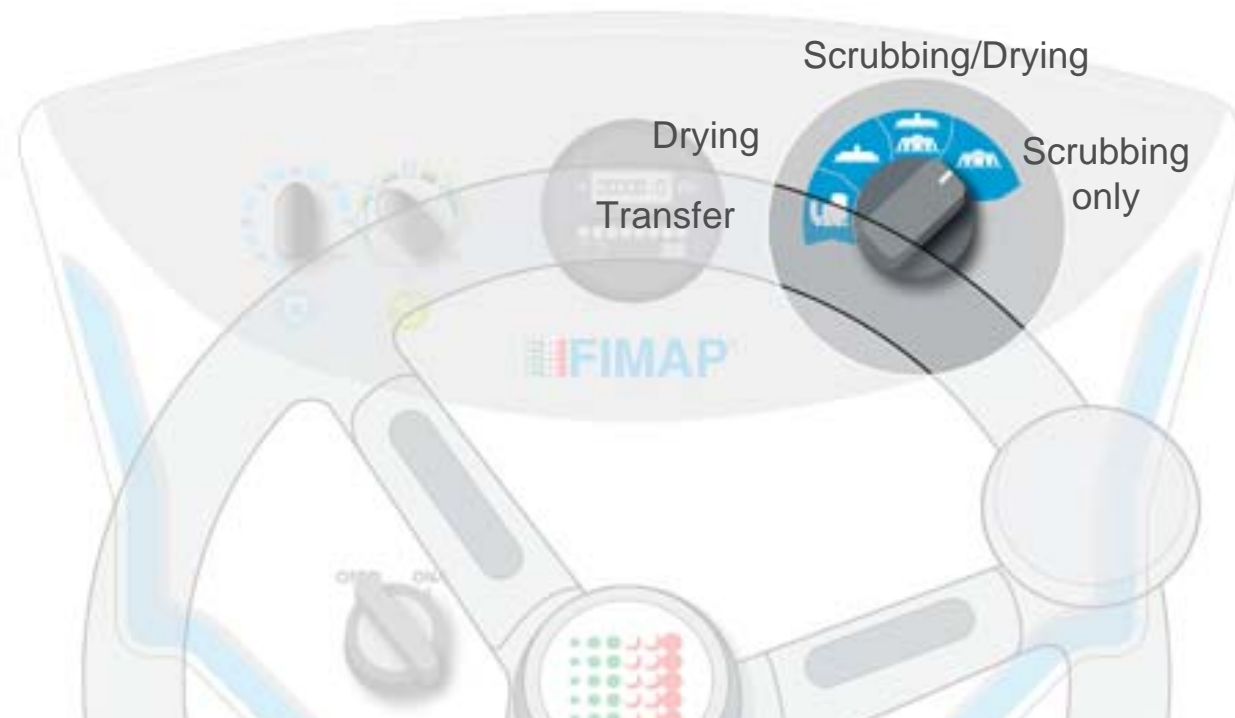

Minimal training for the operator

MMg

User-friendly

... during the cleaning operation



Increase
Pad Pressure &
Water flow with one
pedal – no electronics

Boost cleaning power when 'you' need it

MMg

User-friendly

... during the cleaning operation

Forward and backwards movement



User-friendly and no electronics

Water flow



Easy water flow regulation and no electrics

Service and parking brake

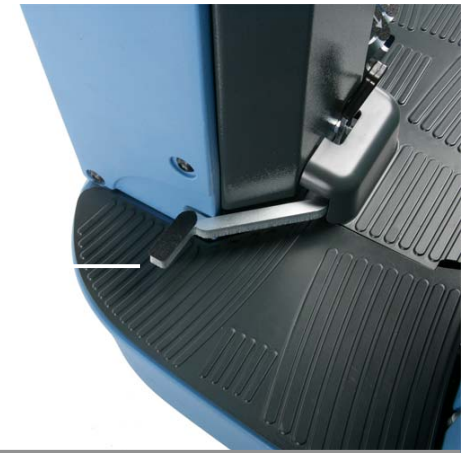

User-friendly and no electronics

... during the cleaning operation

Cleaning along walls

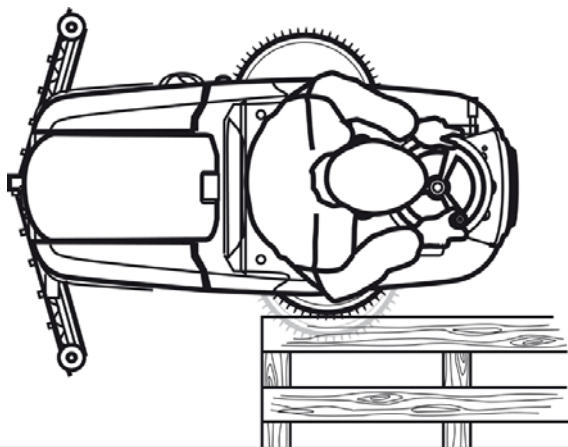

Perfect cleaning along walls without any manual operations

Maximum manoeuvrability

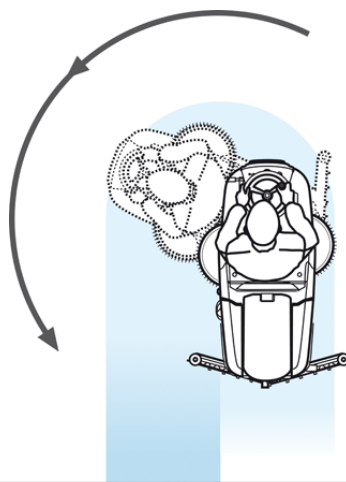

MMg's turn in under two meters

Reduced dimensions



MMg's occupy the same footprint as a walk behind machine but with **TWICE** the productivity

... during the cleaning operation

Low centre of gravity

Wheels

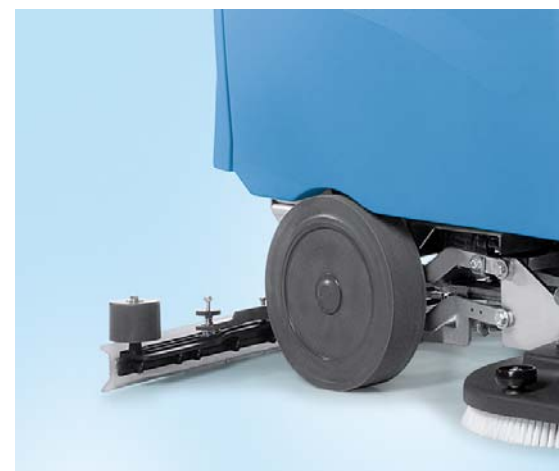
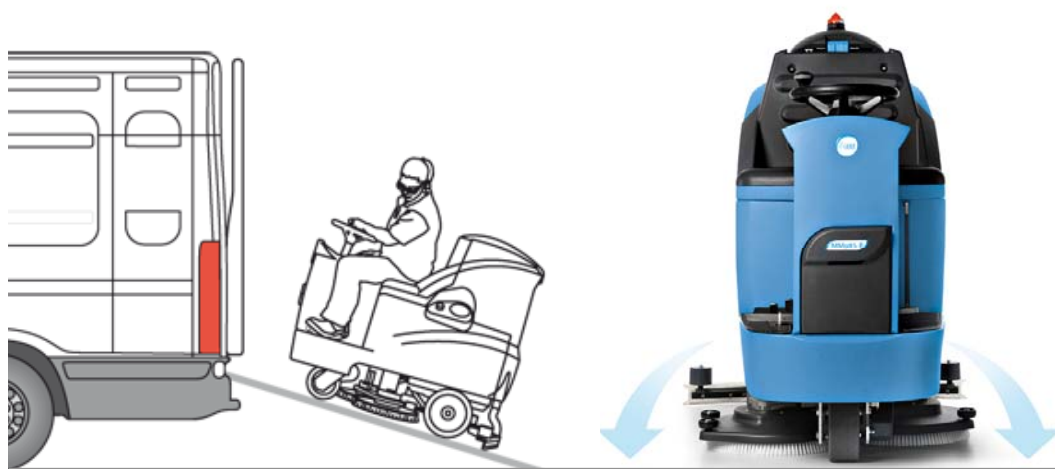

Powerful and safe to use on ramps with gradients up to 18%

Standard fit anti skid and non-marking wheels with a foot brake system for safety on slopes

... during the cleaning operation

Shock proof

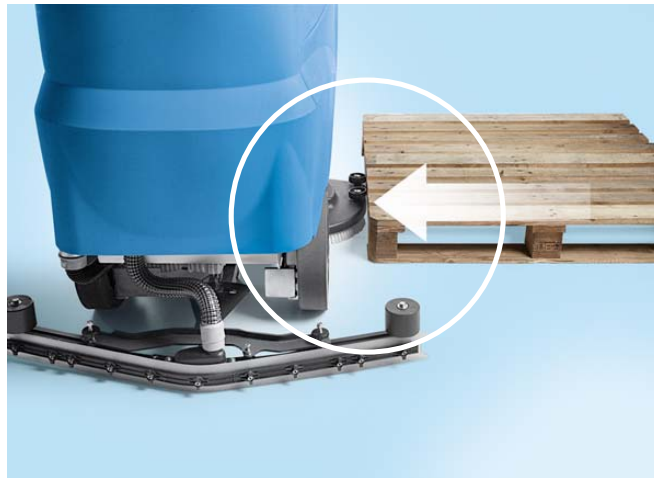

Automatic 'swing-in' of the brush head when accidentally impacted

Break Away

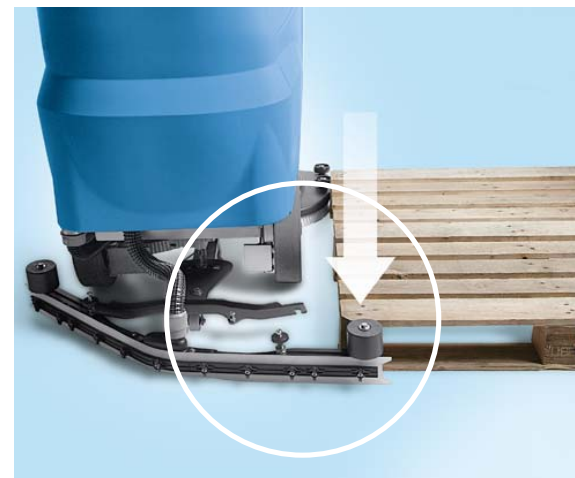

Automatic squeegee uncoupling when accidentally impacted

MMg

Soft maintenance REDUCED

And after work...

Tanks cleaning



Recovery tank discharge
easy to access



Solution tank discharge
easy to access

Suction filter
cleaning



Vacuum filter easy to
access, clean and replace

MMg

Soft maintenance REDUCED

...preparing to work



Battery charging



Easy battery charging thanks to built-in battery charger option

MMg

Soft maintenance REDUCED

Self maintenance...

Tank hygiene



Easy to access,
easy to clean

Squeegee cleaning



Squeegee blades have
four workable edges



NO tool requirement for
squeegee maintenance

**Plastic squeegee and polyurethane
blades are 4 times + longer lasting**

MMg

MMg Dimensions

Tank capacity

Solution: 110 litres
Recovery: 125 litres
Detergent: 5 litre



Working width:
MMg 65B: 650 mm
MMg 75B: 750 mm
MMg 85B: 850 mm
MMg 70 BS: 710 mm



Length:
1485 mm

| Standard equipment | MMg 65/75/85 B - 70 S |
|-------------------------------------------------------------|-----------------------|
| Water and detergent management | |
| FSS (Fimap Solution Saver) | optional |
| FWF (Fimap Water Flow) | • |
| START&STOP | • |
| Fast water filling with drip stop | • |
| Water level indicator | • |
| Scrubbing performance | |
| Adjustable brush pressure | • (no 70 S) |
| Ramp climbing capacity | • |
| Squeegee with polyurethane rubber bars re-usable on 4 sides | • |
| Variable scrubbing head | • |
| 3-stage suction motor | optional |
| Comfort | |
| FNC (Fimap Noise Canceling) | • |
| Fully sanitizable tanks | • |
| Programme selector (i-Drive) | • |
| Step-through access | • |
| On-board battery charger | optional |
| Hour meter | • |
| Battery charge level | • |
| FFF (Fimap Fast Fill) | optional |
| Safety | |
| Anti-skid and non-marking front drive wheel | • |
| Anti-skid and non-marking rear wheels | • |
| Mechanical service and parking brakes | • |
| Flasher | optional |
| Squeegee with shock-resistant coupling (Shock Proof) | • |
| Scrubbing head with impact-elicited swinging in | • |
| Dead man's switch | • |

MMg

Market Positioning



MMg

Segment > Ride on machine 24 V 70/100L

Productivity

- Increased working time
- Mechanical design reduces maintenance time
- Controls designed for easy of use (No specialized user)

Compact

- Excellent performances with reduced dimensions
- Specific pressure up to 40 g/cmq

Ecology

- No energy waste
- Water and detergent saving up to 50%

Ergonomics

- Silent
- Comfortable
- Logical



More flexibility, easier to adjust, greater productivity, **affordable**

MMg

Market Positioning



MMg

| | |  |  |  |  |  |  |  |  | |
|---------------------------|--------------------------------|-----------------------------------------------------------------------------------|-----------------------------------------------------------------------------------|-------------------------------------------------------------------------------------|-------------------------------------------------------------------------------------|-------------------------------------------------------------------------------------|-------------------------------------------------------------------------------------|-------------------------------------------------------------------------------------|-------------------------------------------------------------------------------------|----------------|
| TECHNICAL DATA | | MMg 65/75/85 B | NILFISK BR651 | NILFISK BR755 | TENNANT T7 | KARCHER B90 R Bp | HAKO B650R | IPC CT 110 BT70 | NUMATIC TWIN TECH VARIO | |
| Acoustic level | dB(A) | 58 | 67,5 | 63,7 | 65 | 69 | - | 75 | - | |
| Working width | cm | 65 75 85 | 66 | 71 | 65 | 65 | 65 | 68 | 65 75 85 | |
| | Brushes Ø (N.) | mm | 330 (2) | 330 (2) | 355 (2) | 330 (2) | 365(2) | 330 (2) | 340 (2) | (3) |
| | Supply | V | 24 | 24 | 24 | 24 | 24 | 24 | 24 | 24 |
| Solution Tank | l | 110 | 75 | 106 | 110 | 90 | 116 | 100 | 120 | |
| Recovery Tank | l | 125 | 75 | 106 | 110 | 90 | 116 | 110 | 120 | |
| Working width up to | Sq.m/h | 3900 4500 5100 | 4000 | 9500-3150 | 4160 | 3900 | 4200 | 4200 | 2975 | |
| | Machine dimensions (L x h x w) | mm | 1485x1320x679 | 1450x1310x680 | 1520x1310x770 | 1520x1270x820 | 1450x1200x770 | 1660x1440x800 | 1515x1240x942 | 1676x1425x1054 |
| | Weight (without batteries) | kg | 227 | 140 | 244 | 265 | 150 | 330 | 214 | 500 |
| Squeegee width | mm | 970 1085 1085 | 830 | 830 | 840 | 850 | 850 | 942 | - | |
| Brush rpm | rpm | 140 | 190 | 250 | - | 180 | 195 | 215 | 50-200 | |
| Brush pressure | kg | 30-60 | 30-50 | 40-65-96 | 36-73 | 40 | 40 | 50 | - | |
| Brush motor | V/W | 24/450(2) | 24/400 (2) | 24/480 (2) | 24/400 (2) | 2x600 | 24/820 | 24/300(2) | 24/400 (3) | |
| Traction motor | V/W | 24/400 | 24/600 | 24/1000 | - | 600 | 24/800 | 24/600 | 24/600 | |
| Type of drive | | Aut. | Aut. | Aut. | Aut. | Aut. | aut. | Aut. | Aut. | |
| Turning diameter | mm | 1910 | 1500 | 1630 | 1740 | 1600 | 1690 | - | - | |
| Forward speed | km/h | 6 | 6 | 6,3 | 6,4 | 6 | 6,5 | 6 | 7 | |
| Max gradient at full load | % | Up to 18 | 16 | 16 (9) | 10,5 | 10 | 16 | - | 11 | |
| Suction motor | V/W | 24/350 | 24/500 | 24/560 | 24/550 | 24/420 | 24/550 | 24/560 | 24/500 | |
| Suction vacuum | mbar | 180 | 180 | 157 | 140 | 120 | 170 | - | - | |
| Batteries (N.) | V/A | 6/245 (4) 12/150 (2) | 6/240 (4) | 6/240 (4) | 6/240 (4) | 6/245(4) | 6/240 (4) | 6/245(4) | 6/12 | |
| Batteries weight | kg | 130 | 130 | 130 | 130 | - | - | - | 220 | |
| Total power | W | 1650 | - | 2040 | - | 2 | - | 2000 | 2300 | |

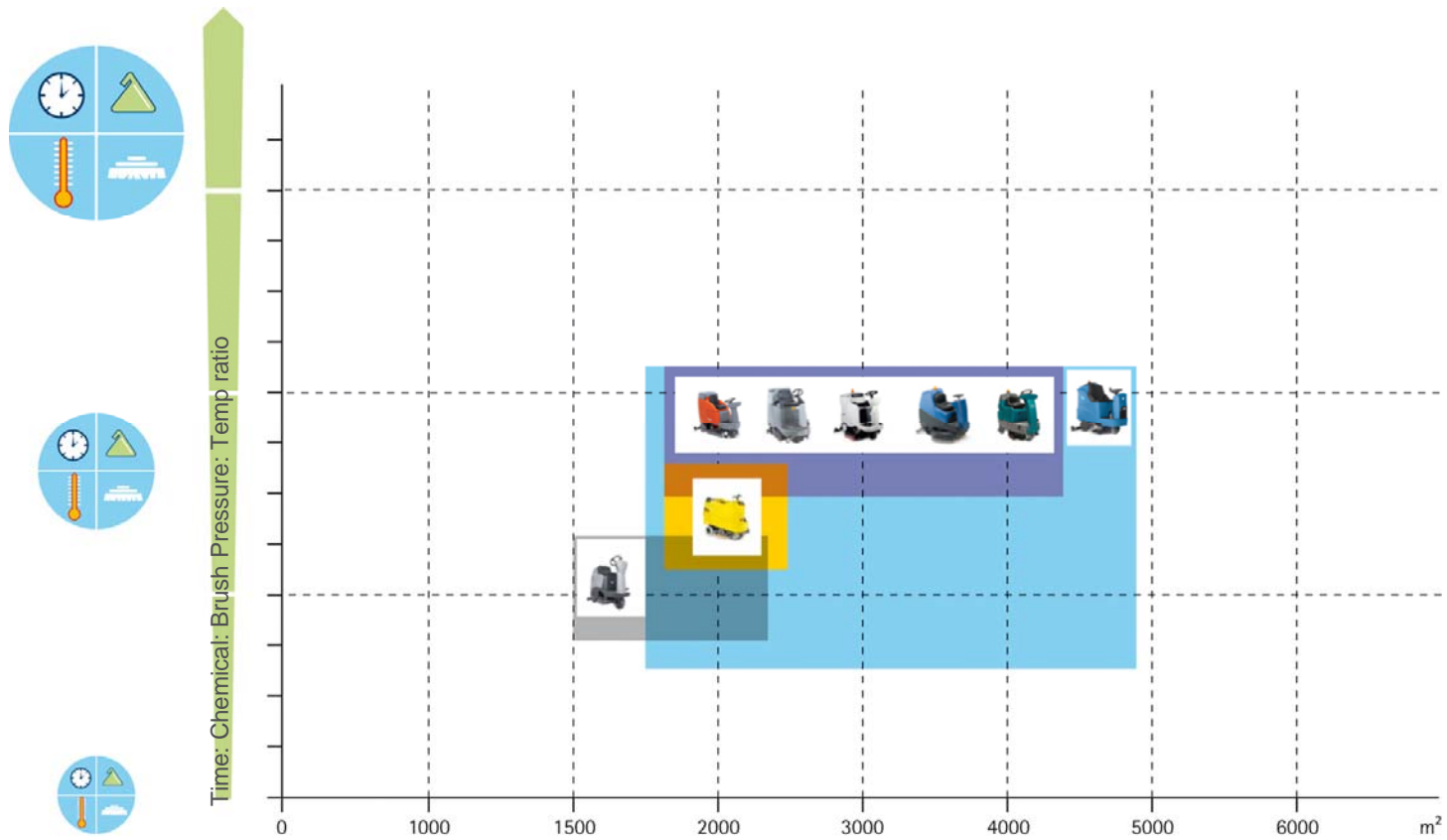

MMg

Market Positioning



MMg

Segment > **Walk-behind**

Productivity

- Faster working speed
- Larger tank capacity, easier to clean
- Easy to use (no specialized user required)

Compact

- Better productivity, similar dimensions
- Better cleaning performance

Ecology

- No energy loss
- Water and chemical saving up to 50%
- Fewer maintenance call outs, no electronic components

Ergonomics

- Silent
- Comfortable
- Logical





More flexibility, easier to adjust, greater productivity, AFFORDABLE

MMg



MMg

| | |  |  |  |
|--------------------------------|--------|-------------------------------------------------------------------------------------|-------------------------------------------------------------------------------------|-------------------------------------------------------------------------------------|
| TECHNICAL DATA | | MMg 65/75/85 B | KARCHER BD60/95RSBp | TASK SWINGO XPI |
| Acoustic level | dB(A) | 58 | 74 | 65 |
| Working width | cm | 65 75 85 | 61 | 75 |
| Brushes Ø (N.) | mm | (2) | 305 (2) | 450x150 (2) |
| Supply | V | 24 | 36 | 24 |
| Solution tank | l | 110 | 95 | 105 flex |
| Recovery tank | l | 125 | 90 | 105 flex |
| Working width up to | Sq.m/h | 3900 4500 5100 | 4200 | 4500 |
| Machine dimensions (L x h x w) | mm | 1485x1320x679 | 1330x1285x690 | 1190x1260x950 |
| Weight (without batteries) | kg | 227 | 243 | 180 |
| Squeegee width | mm | 970 1085 1085 | 830 | 950 |
| Brush rpm | rpm | 140 | 300 | 550 |
| Brush pressure | kg | 30-60 | - | - |
| Brush motor | V/W | 24/450(2) | 36/510 (2) | - |
| Traction motor | V/W | 24/400 | 36/680 | - |
| Type of drive | | Aut. | aut. | Aut. |
| Turning diameter | mm | 1910 | 1300 | 1650 |
| Forward speed | km/h | 6 | 5,6 | 6 |
| Max gradient at full load | % | Fino a 18 | 10 | - |
| Suction motor | V/W | 24/350 | 24/570 | - |
| Suction vacuum | mbar | 180 | 203 | - |
| Batteries (N.) | V/A | 6/245 (4) 12/150 (2) | 12/105 (3) | 6/195 (C5) |
| Batteries weight | kg | 130 | - | - |
| Total power | W | 1650 | 2200 | 1200 |

MMg 70 S

MMg 70 S

Segment > **Scrubber Sweepers as pedestrian machines or ride on ones 24 and 36V**

Productivity

- Increased working speed
- Larger tanks, easy to clean (two separated tank)
- Logical design, easy to use (no specialized user required)
- Vacuumated stainless steel hopper

Compact

- High performances with small dimensions
- One cylindrical brush with frontal dirt tank

Ecology

- No energy loss
- Water and chemical saving up to 50%

Ergonomic

- Silent
- Comfortable
- Logical

More flexibility, easier to adjust, greater productivity, AFFORDABLE

MMg

Fimap Price list trend between 2001 and 2010

Price list index

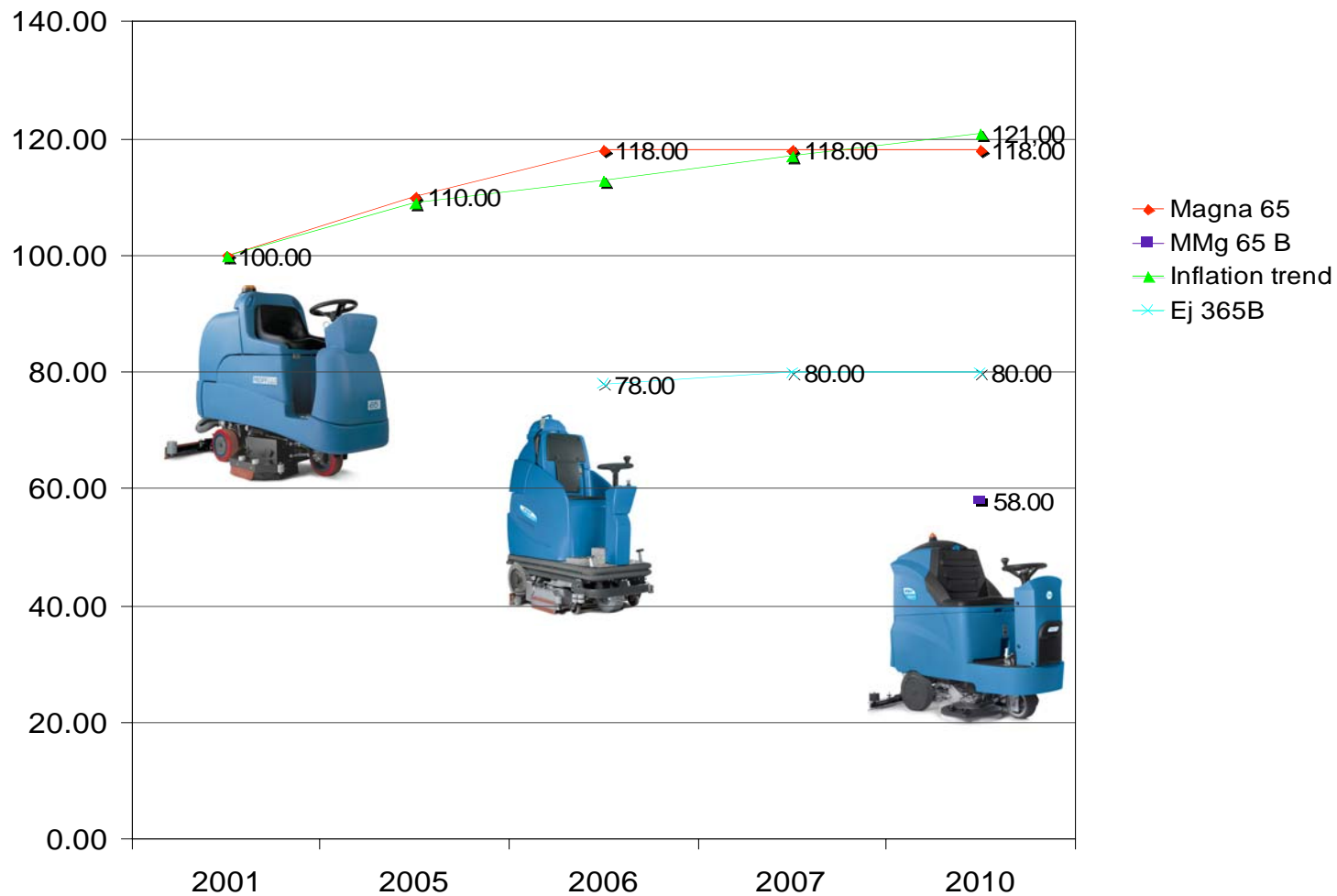

Ownership of the information and/or documents:

All information (by which we mean all data and information with the sole exception of that of common knowledge or which FIMAP has disclosed without reserve) and all documents (drawings, photos, etc.) are the exclusive property of FIMAP and their use does not mean there is any kind of acquisition of titles, property or exploitation of rights or licences except for the limited permission of use ruled by this document.

By way of example and, therefore, not limited to, such information and/or documents can be the following:

Marketing section:

high definition digital images for the implementation of commercial catalogues on paper or web sites, company trademarks, original graphical documents from which texts are taken (e.g. the descriptive notes), PDF documents and original documents in .ppt format.

Professional use of the data:

It is a known fact that the information and/or documents, subject of this commitment, are and will be used by the beneficiary exclusively for carrying out his professional business and, therefore, no specific laws regarding consumer protection are applicable.

Confidentiality:

The Party that benefits from the information or use of documents taken from or, in any case, part of the commercial documentation, shall use all such information and/or documents with maximum care solely for the purposes connected to execution of this contract with FIMAP and shall:

keep such information and/or documents confidential except for those, due to their nature, which are to be disclosed (promo-advertising material etc.);

shall not divulge any information and/or document to its suppliers, collaborators or employees beyond what is strictly necessary so that they may fulfil their tasks concerning relations with FIMAP and shall ensure that the suppliers, collaborators and employees that have access to the information and/or documents are, in turn, bound by a confidentiality commitment to the benefit of FIMAP; shall not divulge any information to third parties without the prior written consent by FIMAP; copy and/or in any other way reproduce any information or document without the prior written consent of FIMAP; take all the necessary measures to protect confidentiality.

Returning Information and/or documents:

Whilst maintaining exclusive ownership at all times, FIMAP has the right, at any time, to ask in writing or by e-mail, that all the information and/or documents received be returned or no longer used and within the term of thirty days from receipt of this request, all the information and/or documents must be returned, including any copies, or destroyed such information and/or documents and relative copies so as to prevent them from being recovered and FIMAP must be given a written declaration certifying that the information and/or documents have all either been returned or destroyed.

This obligation to return, destroy or no longer use is set automatically in motion when the relationship is cancelled with FIMAP for any reason whatsoever.

Applicable law, cancelling clauses and Court having jurisdiction:

The interpretation, integration, execution and the effects of this commitment will be governed by Italian law.

If one or more points of this agreement are cancelled it does not invalidate the remaining points.

All disputes will be put to the exclusive jurisdiction of the Verona Courts.